

In a continued effort to provide cutting edge products and technologies for rupture disk users, ZOOK is pleased to introduce our RA Series of Rupture Disks and Holders. The RA Series offers one unique holder design for use with multiple types of ZOOK *Reverse-Acting* metal rupture disks.

### Features / Benefits

- Pre-Torque Design
  - ...pre-assembly of a rupture disk into a holder prior to field installation
  - ...removal of the assembly from the piping system for inspection without disturbing the seal integrity of the Rupture Disk
  - ...mounting between soft or fragile material flanges (PVC, Glass, etc.) and sealed by using a soft gasket material with low torque on the companion flange bolting
- One *holder* design
  - ...accepts multiple disk designs (RA4, RA6, RA8, and RAX)
- Disk dome is contained within inlet holder
  - ...prevents damaging the disk during installation into mating flanges
- Locating pin
  - ...allows only reverse-acting type disks to be mounted into holder
- Fluoropolymer coated socket head cap screws
  - ...resists corroding to holder assembly
  - ...provides easy removal without special sockets
- Polyethylene cap screw covers
  - ...prevents debris from building up in cap screw head
- Sizes 1" thru 12"
- Standard Holder Materials:  
Carbon Steel, 316SS, Hastelloy
- Holder information is permanently affixed to the O.D. of holder

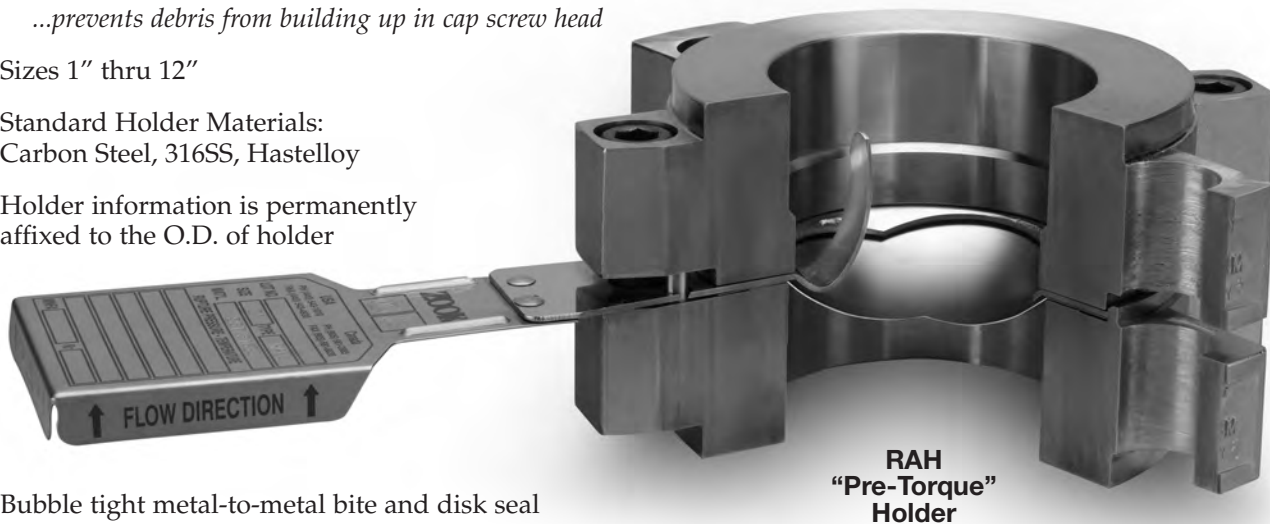

- Bubble tight metal-to-metal bite and disk seal
- Flow direction arrows on disk tag and holder
  - ...provide permanent visual verification that holder assembly is properly oriented in the piping system
- Flange class *and* type specific
  - ...guards against installing an assembly into mating flanges with a different pressure rating than the rupture disk holder
- Positioning hole in mounting lug
  - ...located in the exact position as the mating flange
  - ...allows for proper alignment
  - ...can be used as an extra "hand" when installing into horizontal piping

# Holder Dimensions/Specifications

Nominal Size	Available ANSI Flange Class*	Minimum Height (in)*	Standard Height (in)			Weight (Lbs.) (Short Pattern)	Number of Cap Screws	Cap Screws Hex Size	Gauge tap (NPT)**
			Short Pattern	Mid Pattern	Long Pattern				
1"	150/300/600	1.562	2.126	2.350	2.574	3.8	4	3/16"	1/8"
1-1/2"	150/300/600	1.686	2.250	2.899	3.548	6.4	4	1/4"	1/8", 1/4"
2"	150/300/600	2.158	2.722	3.941	5.160	9.0	4	5/16"	1/8", 1/4"
3"	150/300/600	2.564	3.128	4.928	6.728	16.6	4	3/8"	1/8", 1/4"
4"	150/300	2.592	3.156	5.956	8.756	22.5	4	3/8"	1/8", 1/4"
6"	150/300	3.209	3.444	6.769	10.094	36.0	8	5/16"	1/8", 1/4"
8"	150/300	4.078	4.612	9.037	13.462	53.4	8	3/8"	1/8", 1/4"
10"	150	4.748	5.642	11.167	16.692	99.8	12	3/8"	1/8", 1/4"
12"	150/300	5.059	6.516	13.141	19.766	136.0	12	1/4"	1/8", 1/4"

\* Holders are also available to fit DIN and JIS flanging. Contact ZOOK for details.

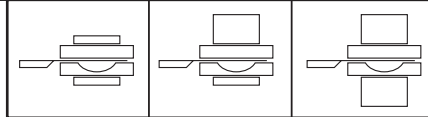

\*Minimum height specified in table above will maintain the pre-torque feature of the rupture disk holder Refer to ASME/ANSI B16.5 Pipe flanges and Flange Fittings (Table 2) for Max allowable Pressure/Temperature Ratings per flange Class

## Options/Accessories

### Mid/Long Pattern

- Can be machined to meet existing piping specifications
- Prevents Rupture Disk membrane from protruding beyond the outlet holder after burst



Replacement Fluoropolymer Coated Cap Screws

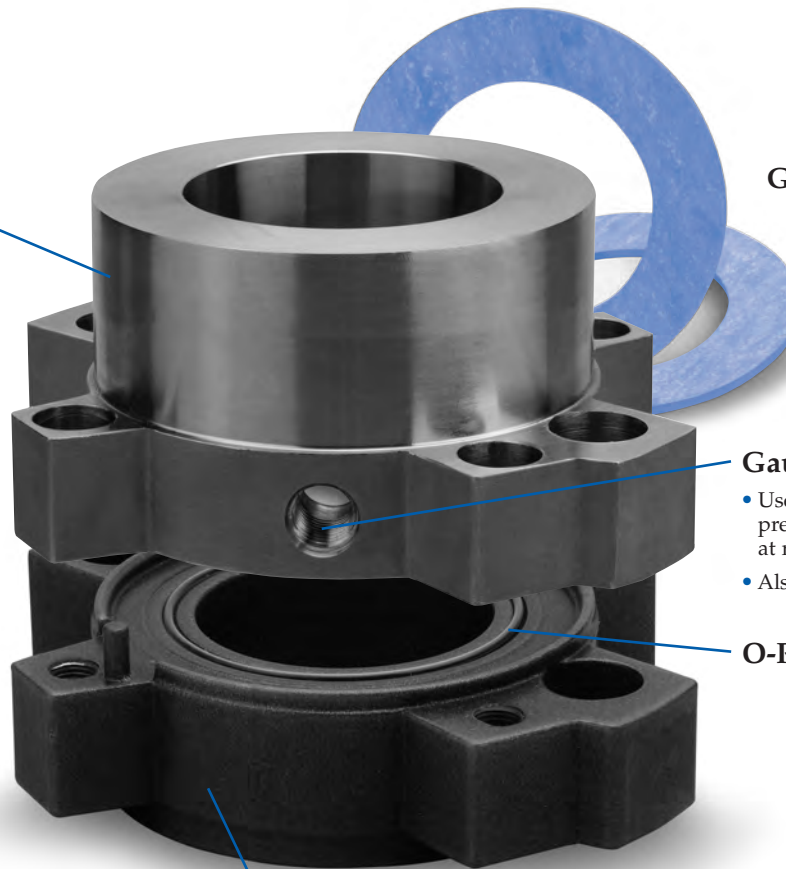

Gaskets

Gauge Tap\*\*

- Used for monitoring pressure/temperature at rupture disk location
- Also available on inlet holder

O-Ring Seal

### Special Coating

- Fluoropolymer Teflon® Sintered (FS)

- Provides durable, non-stick, corrosion resistant surface (Requires O-Ring Seal)

### Cap Screw Specifications\*

Type	Socket Head
Material	Alloy Steel
Hardness	38-43-RC
Threads	UNRF 3A

\*Required to meet Pre-Torque specifications

Teflon - TM DuPont  
Hastelloy - TM Cabot Corp.



**ZOOK Enterprises, LLC**  
16809 Park Circle Drive  
Chagrin Falls, OH 44022 U.S.A.  
Toll Free **800.543.1043**  
Phone **440.543.1010**  
Fax **440.543.4930**  
E-mail **sales@zook.cc**

**ZOOK Canada, Inc.**  
4400 South Service Road  
Burlington, ON Can. L7L 5R8  
Toll Free **800.370.6057**  
Phone **905.681.2885**  
Fax **905.681.8838**  
E-mail **sales.canada@zook.cc**

**ZOOK Europe, LTD.**  
Unit 1.14, Great House Waterside Business Park  
Redwall Close, Rotherham Road  
Dinnington, Sheffield UK. S25 3QA  
Phone **0044 (0) 1909 560999**  
Fax **0044 (0) 1909 560860**  
E-mail **zookeurope@zook.cc**



visit us on the web at [www.zook.cc](http://www.zook.cc)